



WPL

Optimised Line Array – Three-way, bi-amp line array element

Features

- High-performance large format line array
- All-horn, maximum-efficiency design
- Exceptional signature sonic performance
- Exemplary 90° horizontal constant directivity pattern control.
- External, dedicated, multi-channel Class D amplification
- Scalable resolution for flexible optimisation of coverage, consistency and control
- Industry-leading DISPLAY software interacts with DSP for highly-accurate array optimisation
- Fast, integral 3-point rigging for up to 24 enclosures
- Compact and light weight design with discreet side handles for ease of handling

Applications

- Touring sound reinforcement for festivals, stadiums and arenas
- Sports stadium and arena installations
- Concert hall and HoW installations

Wavefront Precision systems deliver unmatched sound quality, coverage consistency and control in an affordable package. Wavefront Precision Longbow (WPL) brings this high performance and control to large-scale touring and install applications from stadium concert and outdoor festivals, to high-specification arena and House of Worship installations.

WPL is designed as a complete system with external iKON® multichannel amplifiers, automated DISPLAY™ optimisation software and VU-NET™ control platform. This guarantees that WPL arrays perform predictably and effortlessly to their design maximum, as well as ensuring that they are compatible with other WPL systems throughout the world.

WPL is a full-scale line array which is capable of exceptionally high output for its modest size and weight. A three-way, bi-amped system, its very high output is achieved by utilising Martin Audio's trademark horn-loading technology across all frequency bands — increasing the acoustic output of the low frequency section, as well as the midrange and HF.

It incorporates 2 x 12" (300mm) drivers with Hybrid® horn/reflex loading, 2 x 6.5" (165mm) cone drivers on a midrange horn which covers the vocal frequency range from 300Hz to over 4kHz, and 3 x 1" (25mm) exit HF drivers operating from 4kHz upwards. Each section features innovative horn-loading techniques and refinements which raise the acoustic performance of WPL to a superior level — both in terms of output and smooth 90° horizontal coverage patterns of the mid and HF horns. Sonically, WPL's exemplary horizontal



dispersion pattern translates to an incredibly consistent frequency response off-axis, with minimal variation from the on-axis response.

The maximum peak outputs of the LF, Mid and HF sections are 139dB, 140dB and 145dB per enclosure @ 1metre respectively — ensuring that a WPL array will meet the most demanding requirements for throw and clarity in the largest venues and outdoor events.

Benefits

- Consistent coverage achieved 'straight-out-of-the-box'
- DISPLAY intelligent software reduces set-up time and eliminates trial-and-error
- Improved audience coverage with reduced sound-spill

WPL

Optimised Line Array – Three-way, bi-amp line array element



Technical Specifications

TYPE	Three-way, bi-amp line array element
FREQUENCY RESPONSE (5)	52Hz-18kHz \pm 3dB
DRIVERS	LF: 2 x 12" (300mm)/3" (75mm) voice coil, ultra-long excursion, neodymium magnet drivers, Hybrid® bass horn loaded MF: 2 x 6.5" (165mm)/2" (50mm) coil, neodymium magnet drivers, horn loaded HF: 3 x 1" (25mm) exit neodymium magnet compression drivers, horn loaded
SYSTEM AMPLIFIER	iKON iK42
SYSTEM RESOLUTION	1 or 2 enclosures per amplifier channel
MAXIMUM SPL (9)	LF: 139dB MF: 140dB HF: 145dB
NOMINAL IMPEDANCE	LF: 8 ohms, MF + HF: 8 ohms
DISPERSION	90° horizontal (-6dB), 120° horizontal (-10dB) 7.5° vertical
CROSSOVER	320Hz active, 4kHz internal passive
ENCLOSURE	Vertical trapezoid with 3.75° wall angle, multi-laminate birch and poplar-ply construction
FINISH	Black textured paint
PROTECTIVE GRILLE	Black HEX perforated steel
CONNECTORS	2 x NL4 type
PIN CONNECTIONS	LF: 1+/1-, MF + HF: 2+/-
FITTINGS	3-point rigging system 4 x side pocket handles
FLOWN ARRAY MAXIMUM	24 enclosures in single array
DIMENSIONS (ex. pins)	(W) 1136mm x (H) 371mm x (D) 526mm (W) 44.7in x (H) 14.6in x (D) 20.7in
WEIGHT	64kg (141lbs)
ACCESSORIES	Touring flying frame Install flying frame Dolly for 4 enclosures Ground stack outrigger Flying Pin

Notes

- (1) Measured on-axis in half (2pi) space at 2 metres, then referred to 1 metre.
- (2) AES Standard ANSI S4.26-1984.
- (3) Measured in half (2pi) space at 2 metres with 1 watt input, using band limited pink noise, then referred to 1 metre.
- (4) Measured in half (2pi) space at 2 metres using band limited pink noise, then referred to 1 metre.
- (5) Measured on-axis in open (4pi) space at 2 metres, then referred to 1 metre.
- (6) Measured in open (4pi) space at 2 metres with 1 watt input, using band limited pink noise, then referred to 1 metre.
- (7) Measured in open (4pi) space at 2 metres using band limited pink noise, then referred to 1 metre.
- (8) Measured in open (4pi) space at 2 metres with 2.83v input, using band limited pink noise, then referred to 1 metre.
- (9) Calculated at 1 metre with 6dB crest factor.
- (10) Measured in half (2pi) space at 2 metres with 2.83V input, using band limited pink noise, then referred to 1 metre.

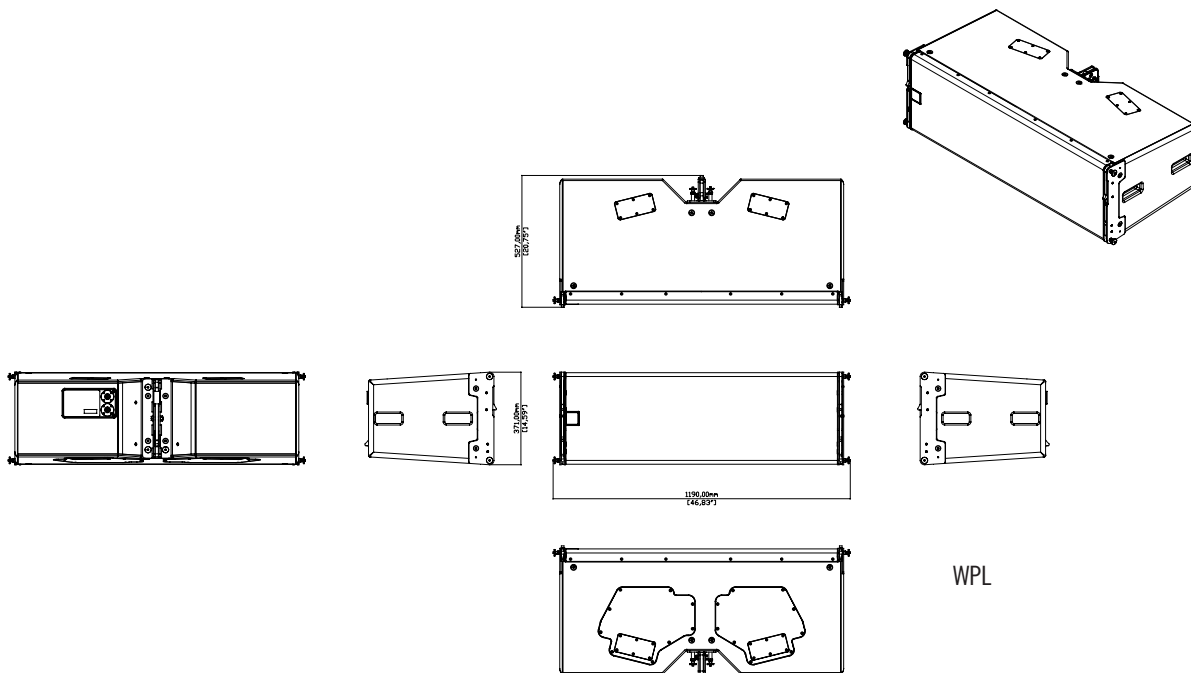



WPL

Optimised Line Array – Three-way, bi-amp line array element

Technical Specifications

iK42 Amplifier

General	
TYPE	Four-channel Class D amplifier
POWER OUTPUT	4 x 5000W into 2 ohms, all channels driven 4 x 3000W into 4 ohms, all channels driven 4 x 1500W into 8 ohms, all channels driven
DIGITAL SIGNAL PROCESSING	96kHz DSP on all inputs and outputs
COOLING	Dual vari-speed fans, front-to-back airflow
MAXIMUM AMBIENT TEMPERATURE	40°C (104°F)
Audio Inputs/Outputs	
ANALOGUE IN/LINK (4 CHANNELS)	4 x female, 4 x male Neutrik™ XLR
ANALOGUE INPUT IMPEDANCE	20kΩ balanced to ground
MAXIMUM ANALOGUE INPUT LEVEL	+20dBu
NOMINAL SYSTEM GAIN	32dB
AES3 IN/LINK (2 CHANNELS)	1 x female, 1 x male Neutrik™ XLR, balanced
DANTE™ (4 CHANNELS)	2 x shielded RJ45, primary and secondary
AMPLIFIER OUTPUTS	4 x Neutrik Speakon™ NL4
Control and Monitoring Network	
PROTOCOL	Ethernet
CONTROL APPLICATION	Martin Audio VU-NET™
Power Supply	
TYPE	High performance Series Resonant
AC INPUT OPERATING RANGE	85 – 240V ~ AC, 47 - 63Hz
MAINS INRUSH CURRENT	6A at 115V, 12A at 230V (max for <10ms)
MAINS CONNECTOR	Neutrik 32A Powercon™
Physical	
DIMENSIONS	(W) 483 x (H) 2U/89mm x (D) 357mm (W) 19in x (H) 2U/3.5in x (D) 14.1in incl handles and optional rear support
WEIGHT	12.5kg (27.5lbs)

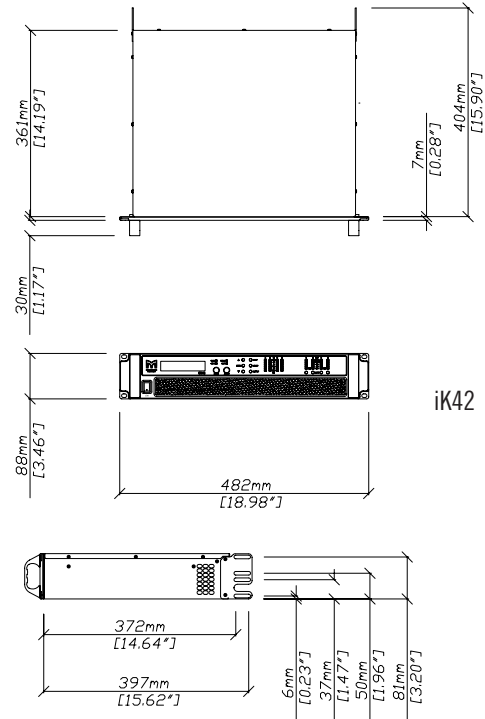

iKON

Trade Descriptions Act

Due to Martin Audio's policy of continuing improvement, we reserve the right to alter these specifications without prior notice. Martin Audio is committed to refining state of the art sound reinforcement, combining in-depth product and field applications research with advanced manufacturing techniques. Every Martin Audio product is built to the highest manufacturing standards and rigorously tested to ensure that it meets the performance criteria specified in the design.

Martin Audio Ltd
Century Point, Halifax Road, High Wycombe
Buckinghamshire HP12 3SL, England

Telephone: +44 (0) 1494 535 312
Email: info@martin-audio.com

All information is Copyright © 2019 Martin Audio Ltd.



www.martin-audio.com

WPL

Optimised Line Array – Three-way, bi-amp line array element



SPL Comparisons Vs Competitors

- The core measurement of SPL is measured differently by manufacturers
- Simply put, many competitors now quote figures based upon a crest factor of 4 (12dB peak vs continuous) and often use the highest sensitivity frequency band (typically HF) to derive their figures given that at LF, where the most power is required, even large amplifiers can't swing twice the peak output volts demanded by a doubling in crest factor from 2 to 4.
- Martin Audio quotes the AES industry standard crest factor of 2 (6dB peak vs continuous) and we ensure our partnering amplifiers are capable of delivering the volts and power to achieve our specs.
- Therefore, if people reading specifications do not understand how SPL is measured and the implications it would appear incorrectly that some competitors have significantly higher SPL.
- While absolute comparable data is not available, some element of logic can be applied for the following products to bring a more realistic comparison.

Product	Peak at Crest factor 2 (6dB)	Peak at Crest factor 4 (12dB)
Martin Audio WPL broadband	139 dB*	145 dB**
Martin Audio WPL HF band	145dB*	151 dB**
d&B KSL12	138 dB**	144dB*
Adamson E12	139 dB**	145dB*
JBL VTXA12	140 dB**	146 dB*
L-Acoustics K2	141 dB**	147 dB*

*Manufacturer quoted

**calculated